

**INFORMACIÓN SOLICITADA SOBRE EL TIPO DE  
TECNOLOGÍA DE LAS LAMPARAS DE ALUMBRADO  
PUBLICO  
UTILIZADAS POR LA MUNICIPALIDAD DE  
SAN DIONISIO 2019.**

**ESPECIFICACIONES TECNICAS**



# LÁMPARA ST-20-45W



## Descripción

FUENTE DE LUZ:	792 LEDS DIP
PESO:	7.2 KG
DIMENSIONES:	520X400X230 MM
CERTIFICACIONES:	CE, ROHS
DISIPADOR DE CALOR:	EXTERNO Y ALUMINIO
CONSUMO ENERGÉTICO:	45 WATTS
FACTOR DE POTENCIA:	> 0.90
VOLTAJE:	85-260VAC
FLUX LUMINARIO:	5000 LUMENS
VIDA ÚTIL:	> 50,000 HORAS
COLOR DE LUZ:	6000k
IP RATING:	IP65
DRIVER:	CON PROTECCIÓN CONTRA DESCARGAS DE AL MENOS 4KVA
GARANTÍA DE LA LÁMPARA:	3 AÑOS



016





# Certificate of Compliance

**Certificate Number: BT0809221001**

**Applicant** : SHENZHEN SINOCO LIGHTING TECHNOLOGIES CO., LTD.  
5/F, Building 2, Hongfa Industrial Park, Tangtou, Shiyan, Bao'an,  
Shenzhen, Guangdong, China

**Manufacturer** : SHENZHEN SINOCO LIGHTING TECHNOLOGIES CO., LTD.  
5/F, Building 2, Hongfa Industrial Park, Tangtou, Shiyan, Bao'an,  
Shenzhen, Guangdong, China

**Product** : LED STREET LIGHT

**M/N** : STX<sub>1</sub>-X<sub>2</sub>-X<sub>3</sub>VVX<sub>4</sub>/X<sub>5</sub>/X<sub>6</sub>, {X<sub>1</sub>(Code for Work Voltage),  
X<sub>2</sub>(Shell Code), X<sub>3</sub>(Power), X<sub>4</sub>(LED Quantity),  
X<sub>5</sub>(Light Source Type), X<sub>6</sub>(Code for Color Temperature)}

**Test Standard** : EN55015: 2006+A1:2007  
EN61547: 1995+A1:2000+A2:2003  
EN61000-3-2:2006  
EN61000-3-3:1995+A1:2001+A2:2005

The EUT described above has been tested by us with the listed standards and found in compliance with the council EMC directive 2004/108/EC. It is possible to use CE marking to demonstrate the compliance with this EMC Directive.

The certificate applies to the tested sample above mentioned only and shall not imply an assessment of the whole production. It is only valid in connection with the test report number: BTRE0809221101.



Christina  
Manager  
Sep.23,2008

**Shenzhen BST Technology Co.,Ltd.**

3F,Weames Technology Building, No. 10 Kefa Road, Science Park, Nanshan District, Shenzhen, Guangdong, China

Tel:86-755-26747751~3 (100 lines) Fax:86-755-26504032 <http://www.bst-lab.com>

017





# Certificate of Compliance

Certificate Number: BTRS0809223001

**Applicant** : SHENZHEN SINOCO LIGHTING TECHNOLOGIES CO., LTD.  
5/F, Building 2, Hongfa Industrial Park, Tangtou, Shiyan, Bao'an,  
Shenzhen, Guangdong, China

**Manufacturer** : SHENZHEN SINOCO LIGHTING TECHNOLOGIES CO., LTD.  
5/F, Building 2, Hongfa Industrial Park, Tangtou, Shiyan, Bao'an,  
Shenzhen, Guangdong, China

**Product** : LED STREET LIGHT

**M/N** : STX<sub>1</sub>-X<sub>2</sub>-X<sub>3</sub>V<sub>1</sub>X<sub>4</sub>/X<sub>5</sub>/X<sub>6</sub>, {X<sub>1</sub>(Code for Work Voltage),  
X<sub>2</sub>(Shell Code), X<sub>3</sub>(Power), X<sub>4</sub>(LED Quantity),  
X<sub>5</sub>(Light Source Type), X<sub>6</sub>(Code for Color Temperature)}

**Test Standard** : EPA3050B:1996, EN1122:2001,  
EPA3052:1996, EPA3060A,  
EPA7196, EPA3540C, EPA8270C

The EUT described above has been consolidated by us and found in compliance with the council RoHS directive—2002/95/EC.

## RoHS

Christina

Assistant Manager

Sep. 23, 2008

Shenzhen BST Technology Co., Ltd.

3F, Weames Technology Building, No. 10 Kefa Road, Science Park, Nanshan District, Shenzhen, Guangdong, China

Tel: 86-755-26747751-3 | 100 lines | Fax: 86-755-26504032 | <http://www.bst-lab.com>

018

**EQ Led**  
Technology meets nature



## LÁMPARA DY2005-60W

---

### Descripción

---

FUENTE DE LUZ:	72 LEDS DE 3030 SMD
PESO NETO:	5.8 KG
DIMENSIONES:	640x265x110 MM
CERTIFICACIONES:	CE, ROHS
CONSUMO ENERGÉTICO:	60 WATTS
FACTOR DE POTENCIA:	> 0.90
VOLTAJE:	85-260VAC
FLUX LUMINARIO:	7200 LUMENS
ANGULO DE LUZ:	150° X 75°
DISIPADOR DE CALOR:	EXTERNO Y ALUMINIO
VIDA ÚTIL:	> 50,000 HORAS
IP RATING:	IP65
DRIVER:	CON PROTECCIÓN CONTRA DESCARGAS DE AL MENOS 4KV A
GARANTÍA DE LA LÁMPARA:	3 AÑOS

---

**EASTY**  
LED SOLUTIONS

019  
**ECOLED**<sup>®</sup>  
Technology meets nature.  
*[Handwritten signature]*

Shenzhen BCTC Technology Co.,Ltd.  
No.101, Yousong Road, Longhua New District,  
Shenzhen, Guangdong, P.R.China



# Certificate of Compliance

Certificate Number: BCTC-LH161011644C

**Applicant** : NINGBO EASTY ELECTRONIC CO., LTD  
NO490 ZHAOLONG ROAD,ZHENHAI NINGBO CHINA.

**Manufacturer** : NINGBO EASTY ELECTRONIC CO., LTD  
NO490 ZHAOLONG ROAD,ZHENHAI NINGBO CHINA.

**Product** : LED STREETLIGHT

**Trademark** : 

**M/N** : DY-STN  
DY2001,DY2002,DY2003,DY2004,DY2005,DY2006,DY2007,DY2008,  
DY2009, DY2010, DY2011, DY2012, DY2013, DY2014, DY2015, DY2016,  
DY2017, DY2018, DY2019, DY2020, DY2021,DY2022,DY2023,DY2024,  
DY2025, DY2026, DY2027, DY2028, DY2029, DY2030, DY2031,DY2032,  
DY2033, DY2101, DY2102, DY2103, DY2104, DY2105, DY2106, DY2107,  
DY2108, DY2109, DY2110, DY2112, DY2113.

**Test Standard** : IEC62321-1:2013

The EUT described above has been consolidated by us and found in compliance with the council RoHS directive—2011/65/EU. It is possible to use CE marking to demonstrate the compliance with this RoHS Directive.



This certificate of conformity is based on a single evaluation of the submitted sample(s) of the above mentioned product. It does not imply an assessment of the whole product and relevant. Directives have to be observed.

Tel: 400-788-9558 0755-33019988  
Http://www.bctc-lab.com Http://www.bctc-lab.com.cn



**ELC Led**  
Technology meets nature.

021

Shenzhen BCTC Technology Co.,Ltd.  
No.101, Yousong Road, Longhua New District,  
Shenzhen, Guangdong, P.R.China



# Certificate of Compliance

Certificate Number: BCTC-LH161011642C

**Applicant** : NINGBO EASTY ELECTRONIC CO.,LTD  
NO490, ZHAOLONG ROAD, ZHENHAI NINGBO CHINA.

**Manufacturer** : NINGBO EASTY ELECTRONIC CO.,LTD  
NO490, ZHAOLONG ROAD, ZHENHAI, NINGBO, CHINA.

**Product** : LED STREETLIGHT

**Trademark** : 

**M/N** : DY-STN  
DY2001, DY2002, DY2003, DY2004, DY2005, DY2006, DY2007, DY2008,  
DY2009, DY2010, DY2011, DY2012, DY2013, DY2014, DY2015, DY2016,  
DY2017, DY2018, DY2019, DY2020, DY2021, DY2022, DY2023, DY2024,  
DY2025, DY2026, DY2027, DY2028, DY2029, DY2030, DY2031, DY2032,  
DY2033, DY2101, DY2102, DY2103, DY2104, DY2105, DY2106, DY2107,  
DY2108, DY2109, DY2110, DY2112, DY2113

**Test Standard** : EN 55015:2013+A1:2015  
EN 61000-3-2:2014, EN 61000-3-3:2013  
EN 61547:2009  
EN 61000-4-2:2009, EN 61000-4-3: 2006+A1:2008+A2:2010  
EN 61000-4-4:2012, EN 61000-4-5:2014  
EN 61000-4-6:2014, EN 61000-4-8:2010, EN 61000-4-11:2004

The EUT described above has been tested by us with the listed standards and found in compliance with the council EMC Directive 2014/30/EU. It is possible to use CE marking to demonstrate the compliance with this EMC Directive. It is only valid in connection with the test report number: BCTC- LH161011642E



This certificate of conformity is based on a single evaluation of the submitted sample(s) of the above mentioned product. It does not imply an assessment of the whole product and relevant Directives have to be observed.

Tel: 400-788-9558 0755-33019988  
Http://www.bctc-lab.com Http://www.bctc-lab.com.cn



020

# LÁMPARA DY2005-120W



## Descripción

---

FUENTE DE LUZ:	180 LEDS 3030 SMD
PESO NETO:	7 KG
DIMENSIONES:	700X305X110MM
ANGULO DE LUZ:	150° X 75°
DISIPADOR DE CALOR:	EXTERNO Y ALUMINIO
CERTIFICACIONES:	CE, ROHS
CONSUMO ENERGÉTICO:	120 WATTS
FACTOR DE POTENCIA:	> 0.90
VOLTAJE:	85-260VAC
FLUX LUMINARIO:	14400 LUMENS
VIDA ÚTIL:	> 50,000 HORAS
IP RATING:	IP65
DRIVER:	CON PROTECCIÓN CONTRA DESCARGAS DE AL MENOS 4KV A
GARANTÍA DE LA LÁMPARA:	3 AÑOS

---

**EASTY**  
LED SOLUTIONS

**ECOled**  
Technology meets nature  
*Signature*



Shenzhen BCTC Technology Co.,Ltd.  
No.101, Yousong Road, Longhua New District,  
Shenzhen, Guangdong, P.R.China



# Certificate of Compliance

Certificate Number: BCTC-LH161011642C

**Applicant** : NINGBO EASTY ELECTRONIC CO.,LTD  
NO490, ZHAOLONG ROAD, ZHENHAI NINGBO CHINA.

**Manufacturer** : NINGBO EASTY ELECTRONIC CO.,LTD  
NO490, ZHAOLONG ROAD, ZHENHAI, NINGBO, CHINA.

**Product** : LED STREETLIGHT

**Trademark** : 

**M/N** : DY-STN  
DY2001, DY2002, DY2003, DY2004, DY2005, DY2006, DY2007, DY2008,  
DY2009, DY2010, DY2011, DY2012, DY2013, DY2014, DY2015, DY2016,  
DY2017, DY2018, DY2019, DY2020, DY2021, DY2022, DY2023, DY2024,  
DY2025, DY2026, DY2027, DY2028, DY2029, DY2030, DY2031, DY2032,  
DY2033, DY2101, DY2102, DY2103, DY2104, DY2105, DY2106, DY2107,  
DY2108, DY2109, DY2110, DY2112, DY2113

**Test Standard** : EN 55015:2013+A1:2015  
EN 61000-3-2:2014, EN 61000-3-3:2013  
EN 61547:2009  
EN 61000-4-2:2009, EN 61000-4-3: 2006+A1:2008+A2:2010  
EN 61000-4-4:2012, EN 61000-4-5:2014  
EN 61000-4-6:2014, EN 61000-4-8:2010, EN 61000-4-11:2004

The EUT described above has been tested by us with the listed standards and found in compliance with the council EMC Directive 2014/30/EU. It is possible to use CE marking to demonstrate the compliance with this EMC Directive. It is only valid in connection with the test report number: BCTC- LH161011642E



This certificate of conformity is based on a single evaluation of the submitted sample(s) of the above mentioned product. It does not imply an assessment of the whole product and relevant. Directives have to be observed.

Tel: 400-788-9558 0755-33019988  
Http://www.bctc-lab.com Http://www.bctc-lab.com.cn



023

Shenzhen BCTC Technology Co.,Ltd.  
No.101, Yousong Road, Longhua New District,  
Shenzhen, Guangdong, P.R.China



# Certificate of Compliance

**Certificate Number: BCTC-LH161011644C**

**Applicant** : NINGBO EASTY ELECTRONIC CO., LTD  
NO490 ZHAOLONG ROAD,ZHENHAI NINGBO CHINA.

**Manufacturer** : NINGBO EASTY ELECTRONIC CO., LTD  
NO490 ZHAOLONG ROAD,ZHENHAI NINGBO CHINA.

**Product** : LED STREETLIGHT

**Trademark** : 

**M/N** : DY-STN  
DY2001,DY2002,DY2003,DY2004,DY2005,DY2006,DY2007,DY2008,  
DY2009, DY2010, DY2011, DY2012, DY2013, DY2014, DY2015, DY2016,  
DY2017, DY2018, DY2019, DY2020, DY2021,DY2022,DY2023,DY2024,  
DY2025, DY2026, DY2027, DY2028, DY2029, DY2030, DY2031,DY2032,  
DY2033, DY2101, DY2102, DY2103, DY2104, DY2105, DY2106, DY2107,  
DY2108, DY2109, DY2110, DY2112, DY2113.

**Test Standard** : IEC62321-1:2013

The EUT described above has been consolidated by us and found in compliance with the council RoHS directive—2011/65/EU. It is possible to use CE marking to demonstrate the compliance with this RoHS Directive.



This certificate of conformity is based on a single evaluation of the submitted sample(s) of the above mentioned product. It does not imply an assessment of the whole product and relevant Directives have to be observed.

Tel: 400-788-9558 0755-33019988  
Http://www.bctc-lab.com Http://www.bctc-lab.com.cn





CERTIFICATION  
EUROPE HONGKONG

# Certificate of Registration

Certificate NO: 10133211E

This is to Certify that the Environmental Management System of

**NINGBO EASTY ELECTRONIC CO.,LTD**  
NO.490, ZHAOLONG ROAD, ZHENHAI, NINGBO, CHINA

Has been audited to the following Environmental Management System standard:

## ISO14001:2015

This system is valid for the

**Manufacturing, processing, wholesale, retail involved in environmental management activities of electronic components, plastic products, metal products, auto parts, lighting, household appliances, daily necessities, mould and accessories, LED lighting and accessories**

Date of issue: Feb. 16, 2017

Valid period: Feb. 15, 2020

This certificate will not remain valid only if the certified organization accepts at least one surveillance audit annually within the validity period of the certificate in which the surveillance audit conforming mark is in the designated position on the certificate.



12months	24months
----------	----------

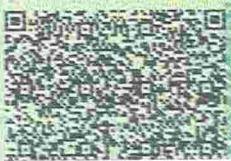

025

Environmental Management System

is ud  
*Tramo*

*Signature*



CERTIFICATION  
EUROPE HONGKONG

# Certificate of Registration

Certificate NO: 10132606Q

This is to Certify that the Quality Management System of  
**NINGBO EASTY ELECTRONIC  
CO.,LTD**

**NO.2, ZHUANGYU ROAD, ZHENHAI, NINGBO, CHINA**

Has been audited to the following Quality Management System standard:

**ISO9001:2015**

This system is valid for the

**Manufacturing, processing, wholesale, retail of electronic  
components, plastic products, metal products, auto parts, lighting,  
household appliances, daily necessities, mould and accessories,  
LED lighting and accessories**

Date of issue: Jun. 07, 2016

Valid period: Jun. 06, 2019

This certificate will not remain valid only if the certified organization  
accepts at least one surveillance audit annually within the validity  
period of the certificate in which the surveillance audit conforming  
mark is in the designated position on the certificate.



028

Issued by:

*Franco*



24months

**EQOLED**  
Technology meets nature

*[Signature]*



## LED

### High Bay Light Ficha Técnica

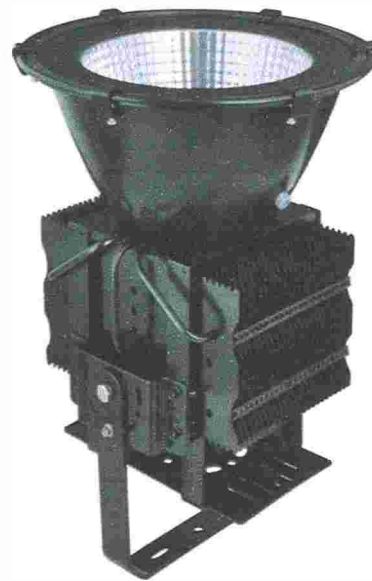
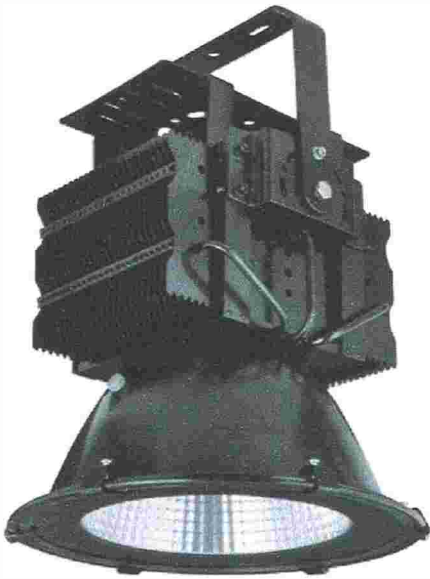

PRODUCTO	<b>DY-HLG</b>
WATAJE	300W

027

# Especificaciones Técnicas:

## REFLECTOR DY-HLG- 300W

---

### Descripción

---

FUENTE DE LUZ:	336 LEDS 3030 SMD
PESO NETO:	15 KG
DIMENCIONES:	670X335X200 MM
CERTIFICACIONES:	CE, ROHS
ANGULO DE LUZ:	150° X 75°
CONSUMO ENERGÉTICO:	300 WATTS
FACTOR DE POTENCIA:	> 0.90
VOLTAJE:	85-260VAC
FLUX LUMINARIO:	36000 LUMENS
VIDA ÚTIL:	> 50,000 HORAS
IP RATING:	IP65
DISIPADOR DE CALOR:	EXTERNO Y ALUMINIO
DRIVER:	CON PROTECCIÓN CONTRA DESCARGAS DE AL MENOS 4KVA
GARANTÍA DE LA LÁMPARA:	5 AÑOS

---

028

# ILUMINACION DE LA LAMPARA :

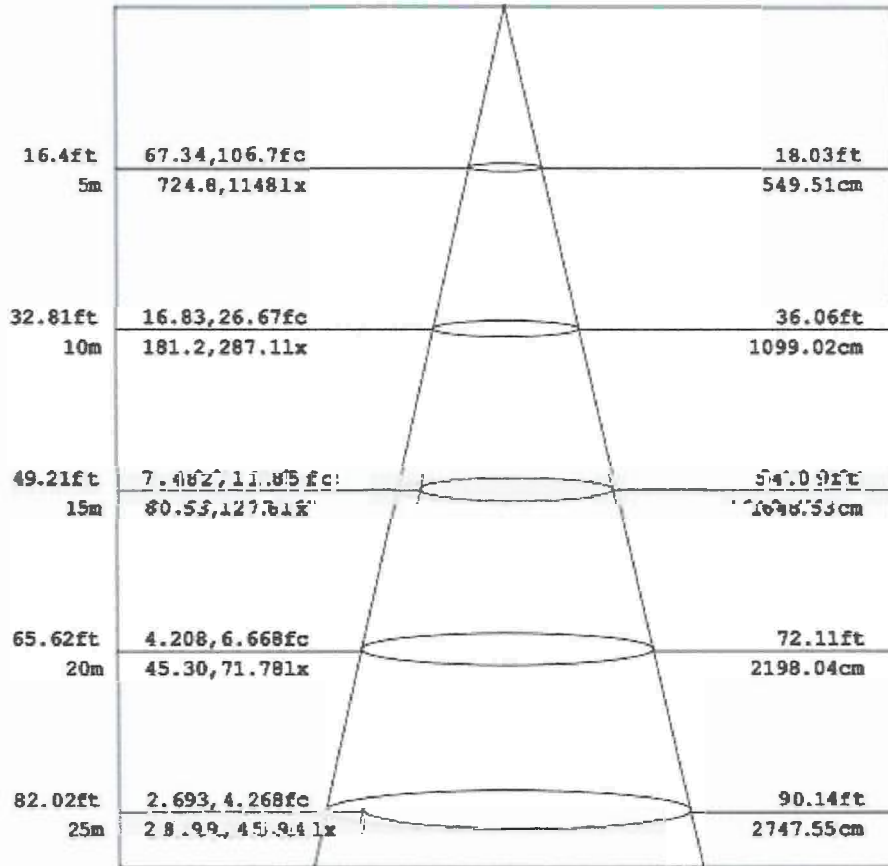

# TAMAÑO DE LA LAMPARA:

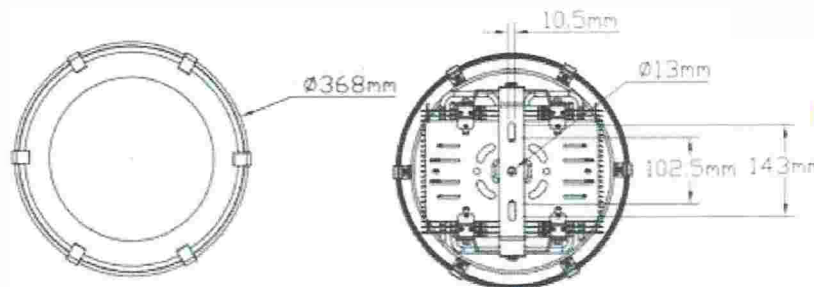
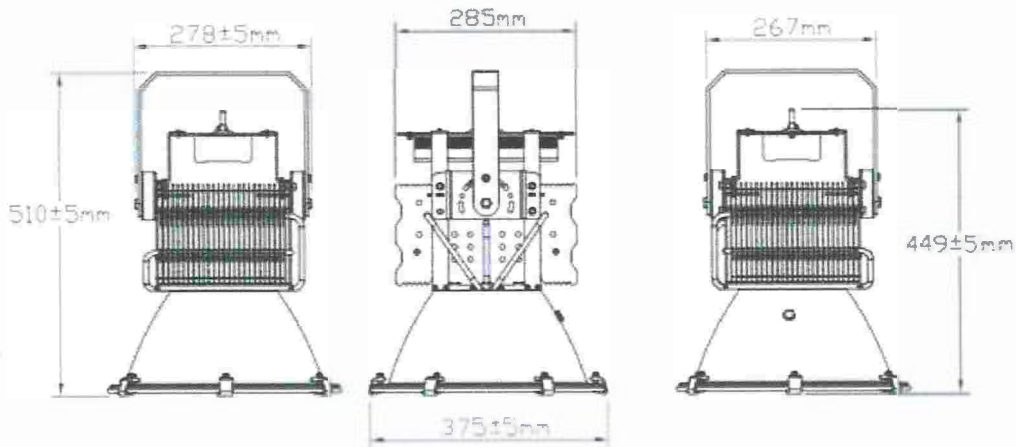

029

**ECOLED**<sup>®</sup>  
Technology meets nature.

*Handwritten signature*

## PAQUETE:

( Caja de embalaje ) : L47\*W47\*H55 CM

Material : K=K

( QTY ) : 1 PCS/CTN

( G.W ) : 11.5KG

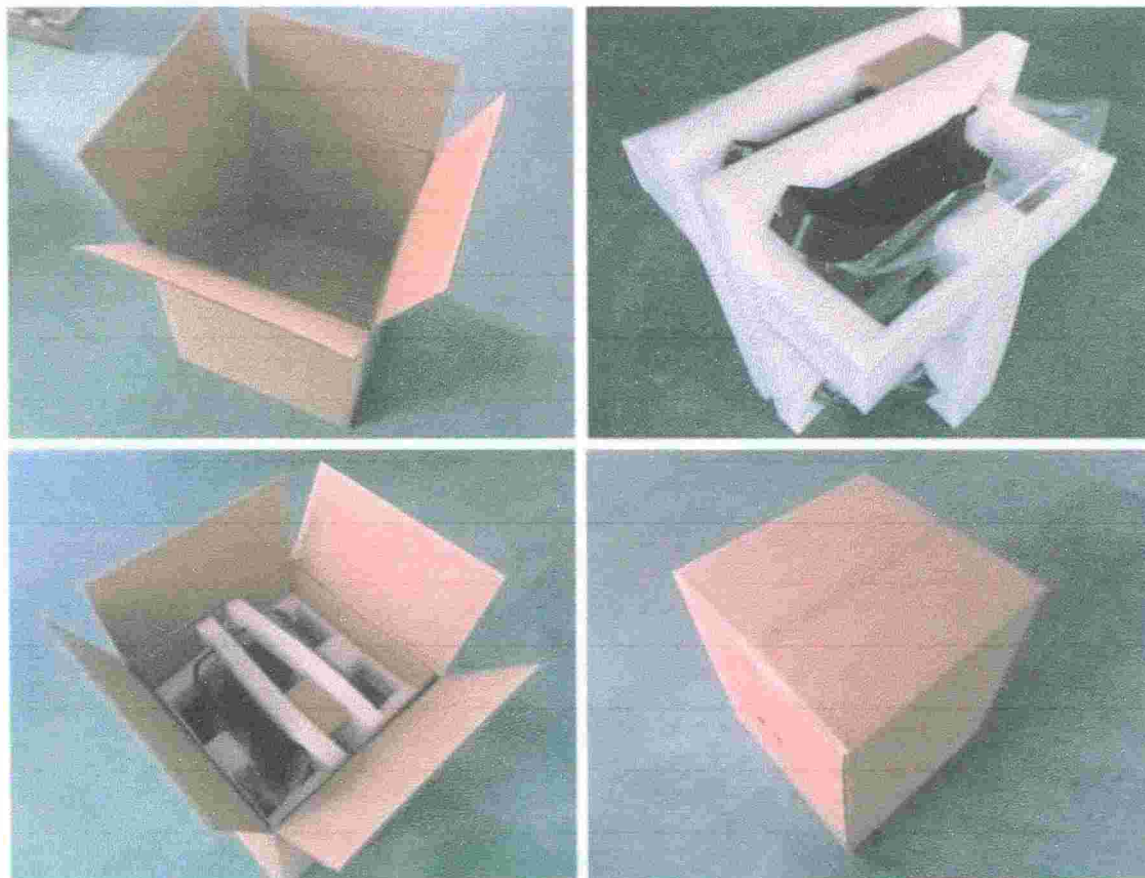

030

**ECOLEN**<sup>®</sup>  
Technology meets nature.

*Vnuw*





Best Service of Testing  
since 2003

# Certificate of Compliance

Certificate NO.: SHBST2014052921YEC-1

Applicant : NINGBO ZHENHAI EASTY ELECTRONIC CO., LTD  
No 490 Zhaolong Road, Zhuangshi Ningbo China

Manufacturer : NINGBO EASTY ELECTRONIC CO., LTD  
No 490 Zhaolong Road, Zhuangshi Ningbo China

Product Name : LED INDOOR LIGHT

Trade Name : 

Main Test Model : DY-HLA

Additional Model : DY-HLN, DY-HLA, DH-HLB, DY-HLC, DY-HLD, DY-HLE, DY-HLF, DY-HLG, DY-HLL, DY-DLC01, DY-DLC02, DY-DLC03, DY-DLC04, DY-DLC05, DY-CLF, DY-CLS, DY-CLA, DY-CLB, DY-CLD, DY-CLD-BLACK, DY-CL, DY-CLH, DY-CLI-COB, DY-CLK, DY-CLL, DY-CL001, DY-CL002, DY-CL003, DY-CL004, DY-CL005, DY-CL006, DY-CL007, DY-CL008, DY-CL009

Test Standard : EN 55015:2013  
EN 61547:2009  
EN 61000-3-2:2006+A1:2009+A2:2009  
EN 61000-3-3:2013

As shown in the Test Report No. : SHBST2014052921YER-1.

The EUT described above has been tested by us with the listed standards and found in compliance with the council EMC directive 2004/108/EC. It is possible to use CE marking to demonstrate the compliance with this EMC Directive.

The certificate applies to the tested sample above mentioned only and shall not imply an assessment of the whole production.



  
Christina  
Manager  
Jun.05,2014

031

Shenzhen BST Technology Co.,Ltd.

Add: Building No.23-24, Zhiheng Industrial Park, Guankouer Road, Nantou, Nanshan District, Shenzhen, Guangdong  
China, Certificate Search: <http://www.bst-lab.com>, Tel:400-882-9628, 8009990305, E-mail:christina@bst-lab.com





Best Service of Testing  
since 2003

# Certificate of Compliance

**Certificate NO: SHBST2014052923YSC-2**

**Applicant** : NINGBO ZHENHAI EASTY ELECTRONIC CO.,LTD  
No 490 Zhaolong Road,Zhuangshi Ningbo China

**Manufacturer** : NINGBO EASTY ELECTRONIC CO.,LTD  
No 490 Zhaolong Road,Zhuangshi Ningbo China

**Product Name** : LED INDOOR LIGHT

**Trade Name** : 

**Main Test Model** : DY-HLA

**Additional Model** : DY-HLN, DY-HLA, DH-HLB, DY-HLC, DY-HLD, DY-HLE, DY-HLF, DY-HLG, DY-HLL, DY-DLC01, DY-DLC02, DY-DLC03, DY-DLC04, DY-DLC05, DY-CLF, DY-CLS, DY-CLA, DY-CLB, DY-CLD, DY-CLD-BLACK, DY-CL, DY-CLH, DY-CLI-COB, DY-CLK, DY-CLL, DY-CL001, DY-CL002, DY-CL003, DY-CL004, DY-CL005, DY-CL006, DY-CL007, DY-CL008, DY-CL009

**Test Standard** : EN 60598-2-1:1989  
EN 60598-1:2008+A11:2009  
EN 61347-2-13:2006  
EN 61347-1: 2008+A1:2011+A2:2013

**As shown in the Test Report No.** : SHBST2014052923YSR-2

The EUT described above has been tested by us with the listed standards and found in compliance with the council LVD directive 2006/95/EC. It is possible to use CE marking to demonstrate the compliance with this LVD Directive.

The certificate applies to the tested sample above mentioned only and shall not imply an assessment of the whole production.



Christina  
Manager

Jun. 05, 2014

032

**Shenzhen BST Technology Co., Ltd.**

Add: Building No.23-24, Zhiheng Industrial Park, Guankouer Road, Nantou, Nanshan District, Shenzhen, Guangdong, China

Certificate Search: <http://www.bst-lab.com>, Tel: 400-882-9628, 8009990305, E-mail: christina@bst-lab.com



Technology meets art



Best Service of Testing  
since2003

# Certificate of Compliance

Certificate NO. : SHBST2014052921YRC-4

Applicant : NINGBO ZHENHAI EASTY ELECTRONIC CO., LTD  
No 490 Zhaolong Road, Zhuangshi Ningbo China

Manufacturer : NINGBO EASTY ELECTRONIC CO., LTD  
No 490 Zhaolong Road, Zhuangshi Ningbo China

Product Name : LED INDOOR LIGHT

Trade Name : 

Main Test Model : DY-HLA

Additional Model : DY-HLN, DY-HLA, DH-HLB, DY-HLC, DY-HLD, DY-HLE, DY-HLF, DY-HLG, DY-HLL, DY-DLC01, DY-DLC02, DY-DLC03, DY-DLC04, DY-DLC05, DY-CLF, DY-CLS, DY-CLA, DY-CLB, DY-CLD, DY-CLD-BLACK, DY-CL, DY-CLH, DY-CLJ-COB, DY-CLK, DY-CLL, DY-CL001, DY-CL002, DY-CL003, DY-CL004, DY-CL005, DY-CL006, DY-CL007, DY-CL008, DY-CL009

Test Standard : EPA3050B:1996, EN1122B:2001, EPA3052:1996, EPA3060A:1996, EPA7196A:1992, EPA3540C:1996, EPA8270D:2007, IEC62321:2008

As shown in the Test Report No. : SHBST2014052921YRR-4.

The EUT described above has been consolidated by us and found in compliance with the council RoHS directive—2011/65/EU.



## RoHS

  
Christina  
Manager  
Jun.05,2014

033

Shenzhen BST Technology Co.,Ltd.

Add: Building No.23-24, Zhiheng Industrial Park, Guankouer Road, Nantou,Nanshan District,Shenzhen,Guangdong, China, Certificate Search: <http://www.bst-lab.com>, Tel:400-882-9628, 8009990305, E-mail:christina@bst-lab.com



